

THE INFORMATION CONTAINED IN THIS DRAWING IS THE SOLE PROPERTY OF ANDERSON POWER PRODUCTS. ANY REPRODUCTION IN PART OR WHOLE WITHOUT THE WRITTEN PERMISSION OF ANDERSON POWER PRODUCTS IS PROHIBITED.

REV.	DESCRIPTION OF CHANGES	BY:	DATE
1	ECRN-14849 CLAMP THICKNESS DIMENSION	TWE	3.8.11

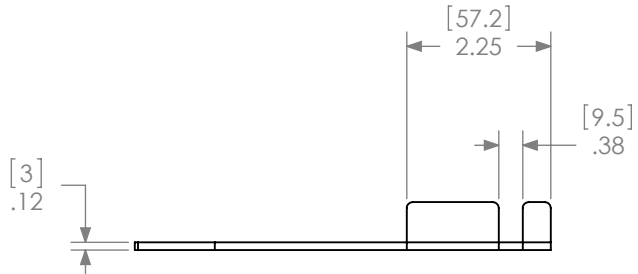
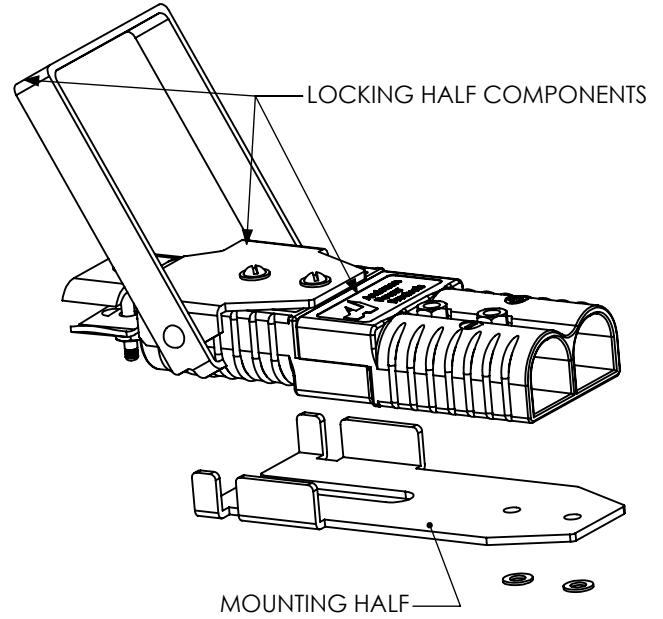
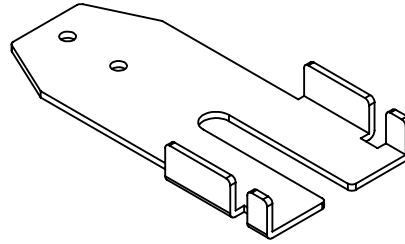
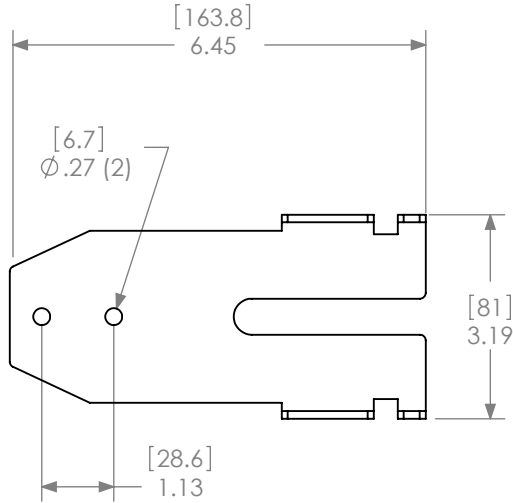

COMPONENTS FOR MOUNTING HALF-  
SB350 MANUAL RELEASE

COMPONENT	QTY
MOUNTING HALF	1
SCREWS	2
WASHERS	2
NUTS	2

- NOTES:  
 1. MATERIAL  
 #11 GA (.120) HOT ROLLED STEEL PICKLED AND OILED  
 ELECTROSTATIC POWDER COAT EPOXY- CRIMSON RED  
 2. USE WITH EITHER CATALOG NUMBER 919 (LOCKING HALF W/ CLAMP)  
 OR 919G1 (LOCKING HALF WITHOUT CLAMP)

NEXT ASSY	USED ON
APPLICATION	

ITEM NO.	PART OR IDENTIFYING NO.	NOMENCLATURE OR DESCRIPTION	MATERIAL SPECIFICATION	QTY REQD
COPYRIGHT 1999 ANDERSON POWER PRODUCTS. ALL RIGHTS RESERVED. UNAUTHORIZED REPRODUCTION HEREBY PROHIBITED.				
DIMENSIONS ARE IN INCHES DIMENSIONS IN PARENTHESES [] ARE IN MILLIMETERS		CAD GENERATED DRAWING, DO NOT MANUALLY UPDATE		<b>ANDERSON POWER PRODUCTS</b>  CATALOG #922G1 SB350 MANUAL RELEASE MOUNTING HALF HARDWARE FOR TRUCK OR CHARGER
TOLERANCES ARE: 2PL- ±.02 [±.5]		APPROVALS	DATE	
MATERIALS: SEE NOTES		DRAWN	CMS 10/15/99	
FINISH SEE NOTES		CHECKED	DJD 10/27/99	
DO NOT SCALE DRAWING		RESP ENG	UFN 10/28/99	
		MFG ENG	CHB 11/1/99	SIZE A
		QUAL ENG	RPO 11/1/99	SPECIFICATION: 114200S1
		SCALE NONE	CADFILES/01129	REV. 1
				SHEET 1 OF 1